

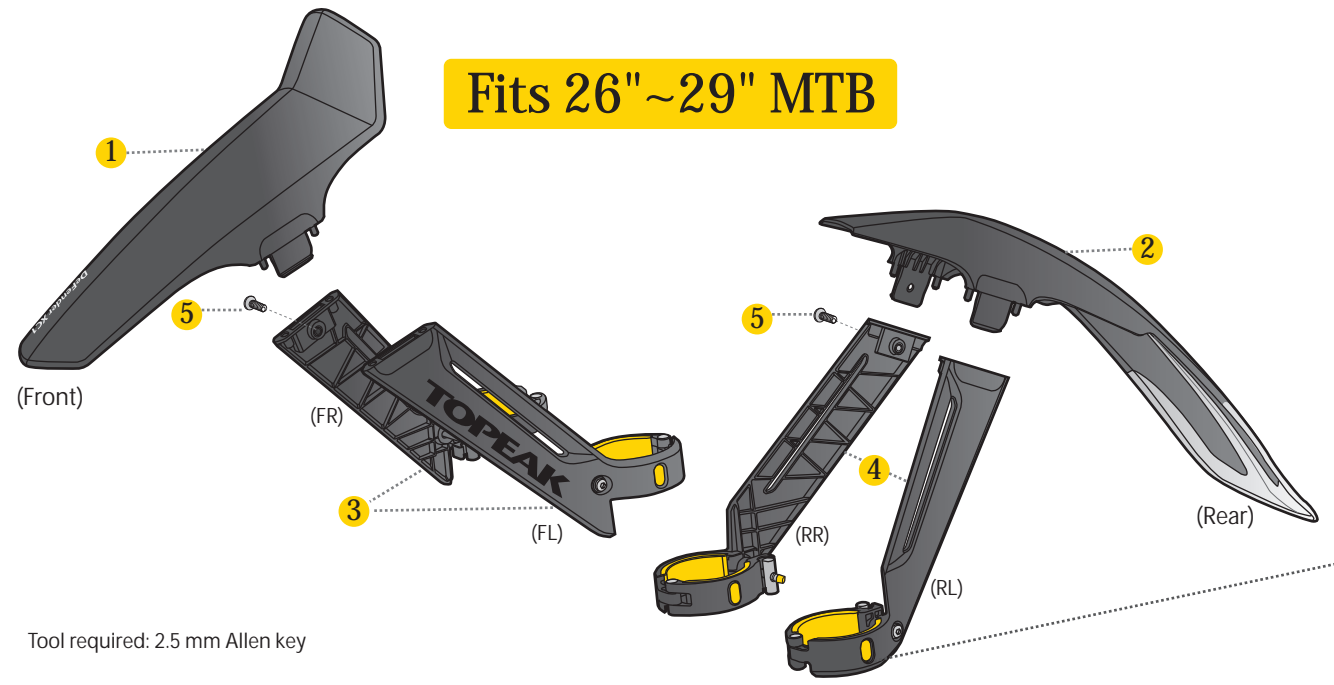

Fits 26"~29" MTB



Tool required: 2.5 mm Allen key

1	2	3	4	5	6	7	8	9	10	11	12	13
Front	Rear	Front Legs (FL) (FR)	Rear Legs (RL) (RR)	M4 x 8mm Bolt x2	Sticker x 2pcs (each)	Foam Spacer x2	2.5 mm Allen key	M4 x 25mm Bolt (Fits ø36~ø40 mm) x4	M4 x 40mm Bolt (Fits ø40~ø48.5 mm) x4	Plastic Washer x4	Nut x4	End Cap x4

Preset M4 x25mm Bolt

Fits ø36~ø40 mm

M4 x 40 mm Bolt

Fits ø40~ø48.5 mm

IMPORTANT NOTE

INSTALLATION

- Use M4 x 8 mm bolts to lock the fender legs on fenders as shown.
- Loosen tension bolt on four fender legs.

Note: Do not loosen the bolt completely.
- Peel backing paper from Foam Spacers. Align and adhere Foam Spacers to XC1 fender (front and rear) as shown.
- Install the rear fender to the fork legs and DO NOT tighten the tension bolts completely. Adjust the rear fender to make sure there is at least 35 mm clearance between fender and tire as shown.

WARNING

- To avoid from hitting the downtube with the rear fender at full fork compression, it is recommended to maintain a 35 mm clearance between the rear fender and tire. Exceeding 35 mm may cause damage to the bike.
- Make sure there is adequate clearance between the fenders and tire width to avoid damaging your bike or fenders.
- Verify fenders are properly adjusted after each installation. Ensure there is enough clearance between fenders, tire and downtube.

- Make sure the rear fender is aligned with tire. Tighten both tension bolts.
- Install the front fender legs right on the top of rear fender's properly and adjust fender to make sure there is at least 35 mm clearance between fender and tire as shown. Tighten both tension bolts.
- Apply both stickers to fenders properly and remove both Foam Spacers.

Note: DeFender XC1 has a disengage function that is activates if a large object enters the wheel. The sticker easily identifies which fender has disengaged from its leg.

IMPORTANT NOTE

The mounting position of XC1 fender (front and rear) can be adjusted to fit various frames and forks.

Fits 26"~29" MTB

IMPORTANT NOTE

A unique design allows front fender to disengage due to any large obstructions entering the wheel.

WARRANTY

2-year Warranty: All mechanical components against manufacturer defects only.

Warranty Claim Requirements

To obtain warranty service, you must have your original sales receipt. Items returned without a sales receipt will assume that the warranty begins on the date of manufacture. All warranties will be void if the product is damaged due to user crash, abuse, system alteration, modification, or used in any way not intended as described in this operating manual.

* The specifications and design are subject to change without notice. Please contact your Topeak dealer with any questions. For USA customer service call : 1-800-250-3068 www.topeak.com

Tool required: 3mm Allen key

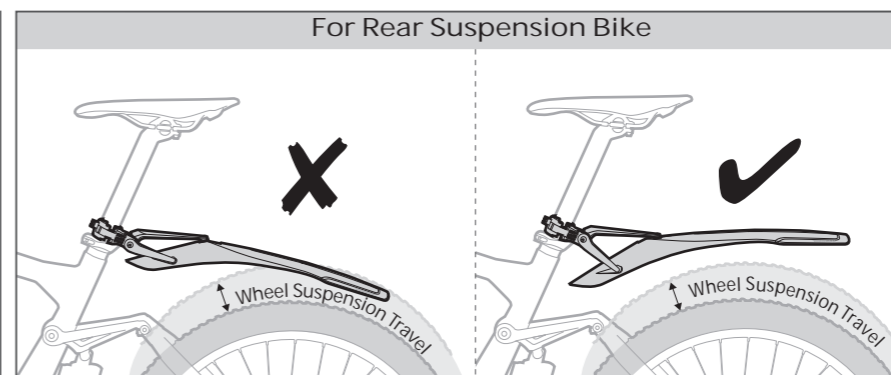
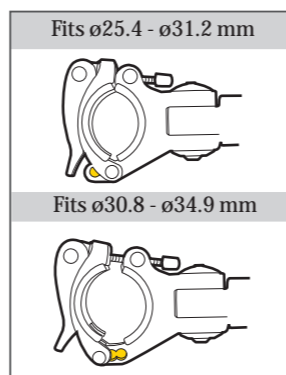
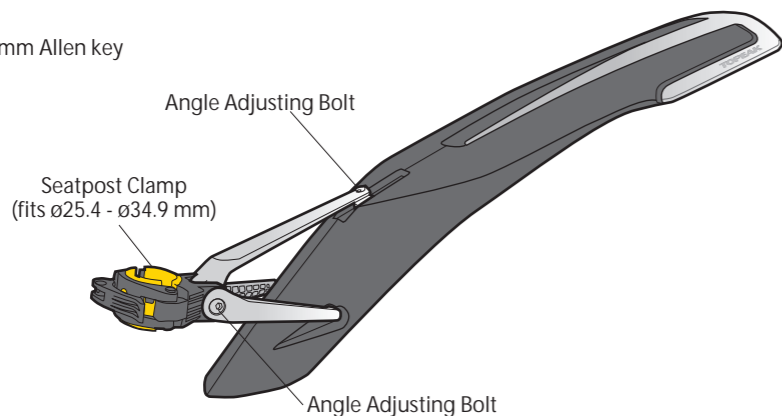

WARNING

When adjusting the angle of DeFender™ XC11, make sure the clearance between DeFender™ XC11 and the tire is larger than wheel suspension travel of the bike. Incorrect clearance may cause damage to DeFender™ XC11, your bike, or potentially cause bodily harm.

SLIP JOINT CLAMP FITS $\varnothing 25.4 - \varnothing 31.2$ mm and $\varnothing 30.8 - \varnothing 34.9$ mm

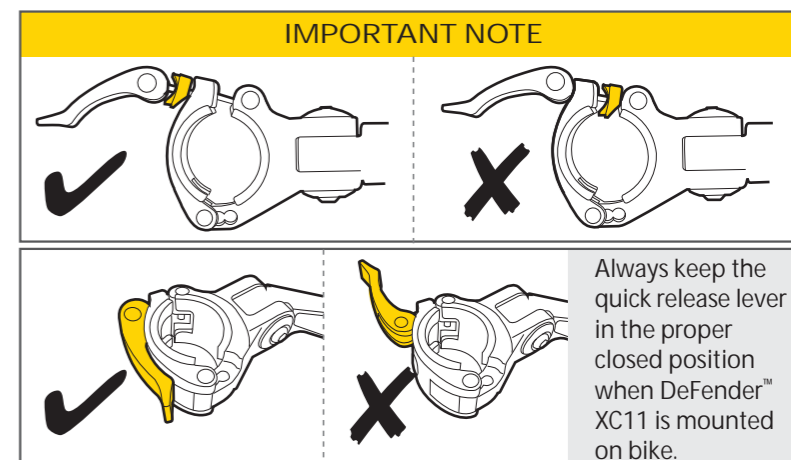
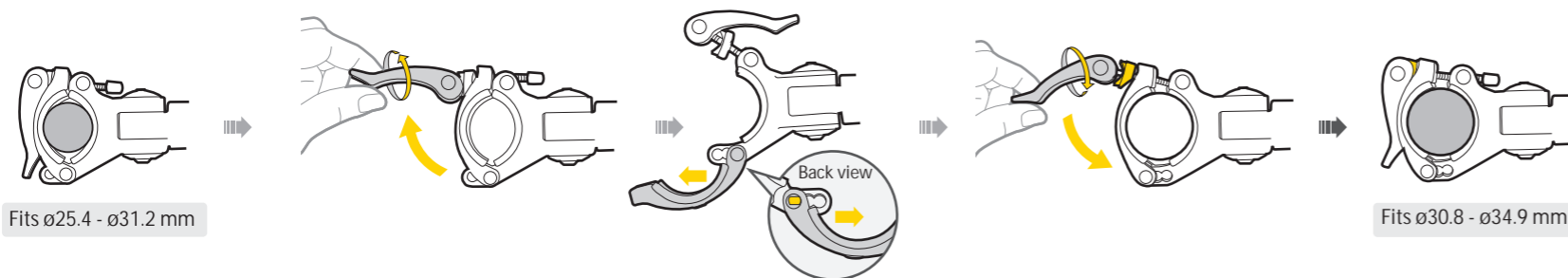

INSTALLATION & ANGLE ADJUSTMENT

INSTALLATION

NOTES :
Loosen angle adjusting bolts first for installation and angle adjustment. Do not loosen them more than 4 counterclockwise rotations or the adjusting bolt assembly will be disassembled and may be damaged.

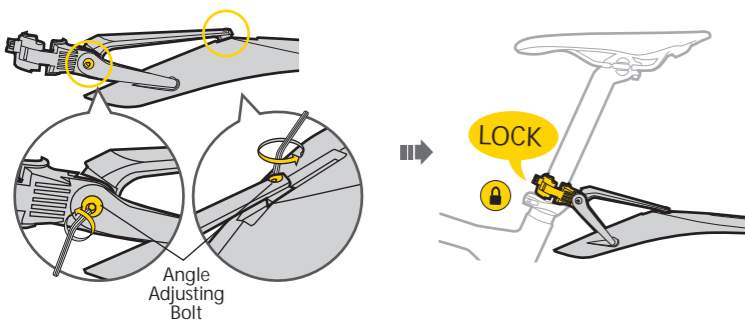

A. DUAL PIVOTS ANGLE ADJUSTMENT

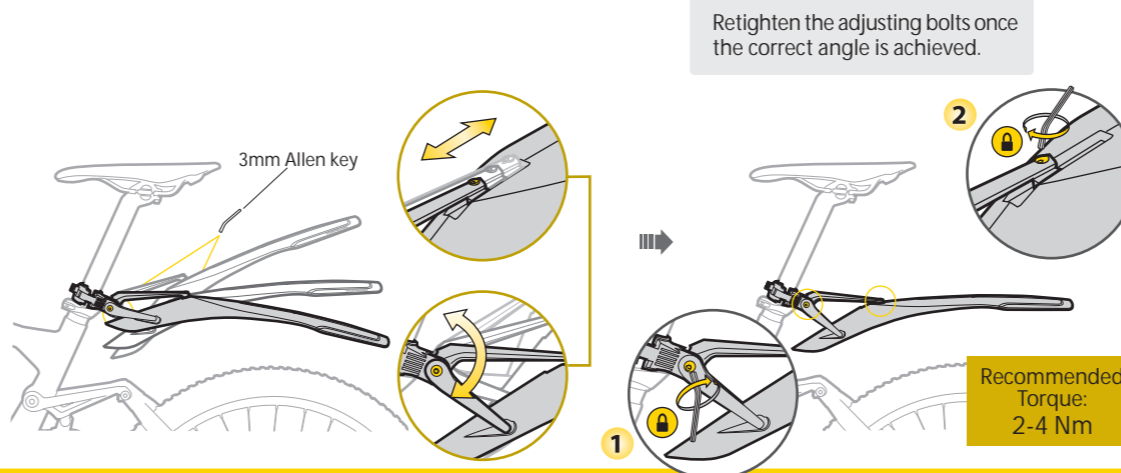

B. ONE PIVOT ANGLE ADJUSTMENT

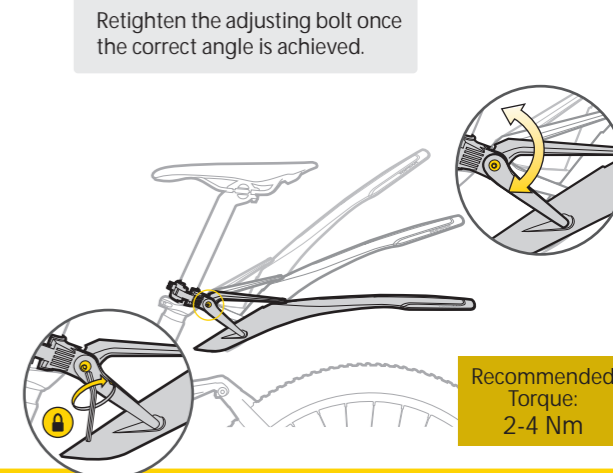

WARRANTY

2-year Warranty: All mechanical components against manufacturer defects only.

Warranty Claim Requirements

To obtain warranty service, you must have your original sales receipt. Items returned without a sales receipt will assume that the warranty begins on the date of manufacture. All warranties will be void if the product is damaged due to user crash, abuse, system alteration, modification, or used in any way not intended as described in this operating manual.

* The specifications and design are subject to change without notice.

Please contact your Topeak dealer with any questions.
For USA customer service call : 1-800-250-3068
www.topeak.com